

# NPR Diesel

## STANDARD CAB

<b>GVWR/GCWR</b>	13,000/19,000 lbs.
<b>BODY/PAYLOAD ALLOWANCE</b>	7,435 - 7,607 lbs.
<b>GAWR</b>	
<i>Front</i>	5,360 lbs.
<i>Rear</i>	9,880 lbs.
<b>FRONT AXLE CAPACITY</b>	6,830 lbs.
<b>REAR AXLE CAPACITY</b>	11,020 lbs.
<i>Ratio</i>	5.125
<b>SUSPENSION F/R SPRINGS</b>	Tapered/Multi-Leaf
<i>Capacity</i>	6,830/9,880 lbs.
<b>FRAME</b>	
<i>Section Modulus</i>	7.20 in. <sup>3</sup>
<i>Resistance Bending Moment</i>	316,800 lb.-ft./in.
<b>SERVICE BRAKES</b>	Vacuum/Hydraulic with
<i>Front/Rear</i>	4-Channel ABS Disc/Drum
<b>EXHAUST BRAKE</b>	Standard
<b>TRANSMISSION</b>	Aisin A460 6-speed auto.
	with double overdrive
	and lock-up 2 <sup>nd</sup> -6 <sup>th</sup> gears
<b>ENGINE</b>	Isuzu 4JJ1-TC turbocharged
	intercooled diesel
<i>Displacement</i>	3.0L (183 in. <sup>3</sup> )
<i>Engine Power</i>	150 hp @ 2,800 rpm
<i>Engine Torque</i>	282 lb.-ft. @ 1,600-2,800 rpm
<i>Oil Level Indicator</i>	Dash-mounted oil level
	check switch and light
<b>LIMITED SLIP DIFFERENTIAL</b>	Optional
<b>ALTERNATOR</b>	140-amp
<b>BATTERIES</b>	2 Maintenance-Free
	750-CCA
<b>TIRES LRR (Low Rolling Resistance)</b>	215/85R16E (10-pr) Standard
<b>STEERING</b>	Integral Hydraulic Power
<b>STEERING COLUMN</b>	Tilt and Telescopic
<b>FUEL TANK</b>	
<i>Standard</i>	30 gal. in-rail
<b>FUEL/WATER SEPARATOR</b>	Dual fuel filter with dash
	mounted indicator light

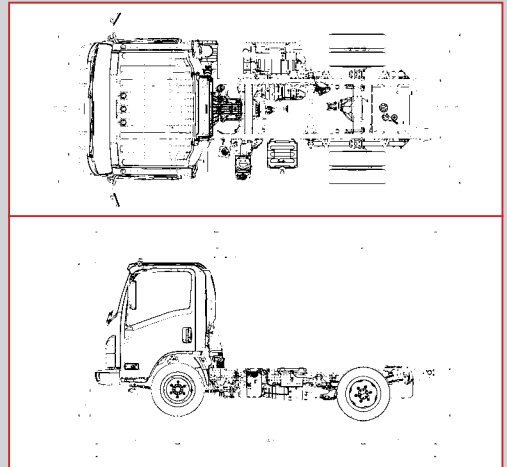

Wheelbase (in.)	Cab to Axle (in.)	Cab to End of Frame (in.)	Back of Cab (in.)	Overall Length (in.)	Body Length (ft.)	Overall Width (in.)	Axle Width (in.)	Overall Height (in.)
109.0	86.5	129.6	6.1	200.5	10-12	81.3	65.6	90.8
132.5	110.0	153.1	6.1	224.0	14	81.3	65.6	90.8
150.0	127.5	170.6	6.1	241.5	16-18	81.3	65.6	90.8
176.0	153.5	196.6	6.1	267.5	18-20	81.3	65.6	90.8

### 2017 ISUZU N-SERIES DIESEL WARRANTY COVERAGE AT A GLANCE

Vehicle Coverage	Warranty Limitations (Time or Mileage, Whichever Comes First)*		Percentage of Dealer's Normal Charge Paid by Owner	
	Time in Years*	Vehicle Miles**	Parts	Labor
Basic	0-3 Years	Unlimited	No Charge	No Charge
Engine	0-3 Years	Unlimited	No Charge	No Charge
• Transmission				
• Drive Axle				
• Driveshaft				
• Front Axle I-Beam	0-3 Years	Unlimited	No Charge	No Charge
• Crossmembers				
• Flywheel Housing				
• Clutch Housing				
Frame Rails	0-3 Years	Unlimited	No Charge	No Charge
	3-5 Years	Unlimited	50%	50%
Engine Emissions Control System - Federal	0-5 Years	0-100,000	No Charge	No Charge
Tires	0-2 Years	0-24,000	No Charge	No Charge
Corrosion (Rust Through)	0-4 Years	Unlimited	No Charge	No Charge

\* The warranty coverage is determined by the mileage of the vehicle and the number of years from the delivery date. \*\* See your authorized Isuzu dealer for warranty details.

